



## The Connective Force

*With the old forces of religious fear, political subjugation and corporate greed finally eradicated from the planet, what force will drive humanity to self-connect into an integrated society?*

email: [robmorton@clara.net](mailto:robmorton@clara.net)      [download PDF \[A4 paper\]](#)

We humans - of all the life-forms on this planet - are uniquely sentient. Our massive 100 billion neurone brains alone are the vessels of conscious minds. We alone among all creatures are, through abstract thought borne within symbolic language, each able to declare in truth: "I think, therefore I am". Through our adaptively deployable bodies, our minds can map and manipulate our domain like no other species. For this we must accept our implicit obligation to be responsible stewards of our terrestrial inheritance and caring shepherds to all creatures with whom we share it.

Probably the most noticeable thing about us - of which we ourselves are most acutely aware - is that we occur in two equally prevalent genders. Apart from slight statistical differences in size and mass, our complementary genders are for the most part identical, yet exhibit slight *mutually pleasing* differences in body shape and emotional disposition. The obvious physical difference between our genders is of course their complementary connective organs. In separation these are functionally inert. It is only when we become appropriately conjoined that together they become a functioning coital subsystem.

We find ourselves driven by a powerful inward *desire to connect*. Yet we seem to spend far less time connected than we would naturally and healthily desire. And we each connect surprisingly infrequently and with surprisingly few of our general counterparts. This in consequence deprives us of adequate emotional and intellectual connectedness.

This strongly suggests to me that monogamy is not our natural way but is a result of societal constraints imposed upon us by present day state, religious and corporate hierarchies. These strive to suppress, pervert or control intimate connection, which is to the extreme detriment of the human condition. It suggests consequently that if all these repressive hierarchies were removed, a *natural force* that now lies inhibited within each of us would drive us to connect naturally into a benign global society.

## Myth of Monogamy

Mainstream society today preaches monogamy. Born out of the enslaving doctrines of religious hierarchies, its legal systems recognise marriage as between one husband and one wife in sexual isolation. It allows no other options. Ideally, a marriage lasts until the death of one or both of the partners. Divorce and remarriage are tolerated, but still only one sexual relationship at a time is officially allowed. Celibacy (having no intimate connection at all) is acceptable, but is in most cases considered to be undesirable because it does not promote the continuance of the human species.

Mainstream doctrine assumes that the amoric drive (or force of sexual attraction) within the human spirit is *monovalent*. That is, each of us has an actual *need* for an intimate connection with only one other person at a time in our lives. It purports that any craving for additional intimate relationships is psychologically dysfunctional.

Interview-based surveys suggest that despite this, inter-marital sex is rife. Though these surveys are notoriously subjective, paternity genetic marker surveys now provide an objective view. These are reputed to show that in populations where men and women have ready access to each other, [at least 1 child in 4](#) born to a wife is not fathered by her husband.

So reality suggests that the human life-form is naturally [polyamorous](#). This is further evinced by the observation that even where monogamy is oppressively imposed, it rapidly defaults away from lifetime monogamy towards an uneasy form of [serial monogamy](#).

But science is not the only voice of reason here. The *ancient texts* - from which the established religious hierarchies claim to have received their monogamist doctrines - when looked at in the social context within which they were written [do not forbid or even disapprove of polyamory](#) but simply assume it.

## Multi-Relational Mind

So it seems that no matter how fulfilling an intimate relationship may be - physically, emotionally or intellectually - one person cannot fulfil *all* of another's needs in these things, simply because that one person is only one other single sentient consciousness. It is as if there are multiple compartments or receptacles built into each human mind or consciousness, within which an intimate relationship can take root and grow.

I imagine these *relationship receptacles* as ethereal spheres within the mind, each containing a complex emotional model of a *very special friend*, each inducing its neighbours to shine more brightly.

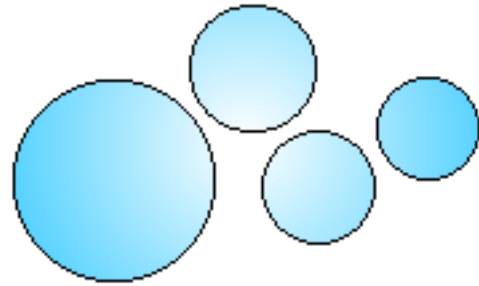

These spheres differ in size, with typically one large primary sphere accompanied by other smaller secondary spheres, each having its *counterpart* within another's mind, with which it grows into ever-closer resonance.

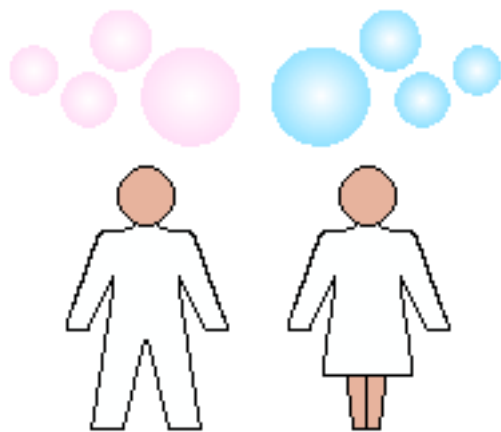

Hence, in the mind of each lady there is an ethereal sphere containing her emotional model of each of the guys she loves. In the mind of each man is an ethereal sphere containing his emotional model of each of the ladies he loves. There is a part of his mind that is forever each lady. There is a part of her mind that is forever each man.

Dare we speculate that perhaps each complementary pair of spheres coalesce within a common hyperspace of human consciousness, thereby uniting the spirits of two loves in a way that only they can feel.

Note that the mind of the male contains pink spheres representing the emotional models of his females, while the mind of the female contains blue spheres representing the emotional models of her males. Thus in the heart of man is woman and in the heart of woman is man.

The number of spheres in an individual's mind represents the number of *concurrent* amoral relationships that person's emotional make-up has equipped them to be able to have. This number is known as that person's *amoral valency* - drawing the analogy with chemical bonding. It must be emphasised here that the term *amoral valency* refers to the number of *concurrent* relationships a person is able to have: not the number of intimate partners they have had throughout their life since sexual initiation.

Each amoral relationship is unique. It contains aspects and qualities no other amoral relationship does or can. Any unfilled sphere leaves its 'owner' emotionally incomplete and lonely - even within a strong permanent monogamous marriage. All must be fulfilled for the individual to be emotionally complete and satisfied. Any unfulfilled sphere seems to generate an irresistible emotional drive to reach out and connect with another vacant sphere languishing

within the mind of an appropriate potential lover.

This powerful emotional drive - or amoral force - powers more than just physical sex. After all, it remains undiminished long after childbearing ability and potency fade. So in humans at least, it must be far more than just a reproductive imperative to carry forward one's genes. It must also drive perhaps a more important communication imperative by which lasting *relationships of the intellect* are formed by combining knowledge and wisdom through the partial union of two independent human spirits. It is these glorious unions - these intimate relationships between sentient consciousnesses - that is what life, the universe and everything is all about.

Now, the more I delve into this subject, the more I am becoming convinced that if the social pressures from state, religious and (surprisingly) commercial institutions were removed, then both sexes of the human species would be seen to have exactly the same range and variations in sexual drive, appetite and valency.

These are of course entirely separate from the obvious gender difference in reproductive role, which in turn belies a comparable slight asymmetry in their emotional perspectives on life and reality.

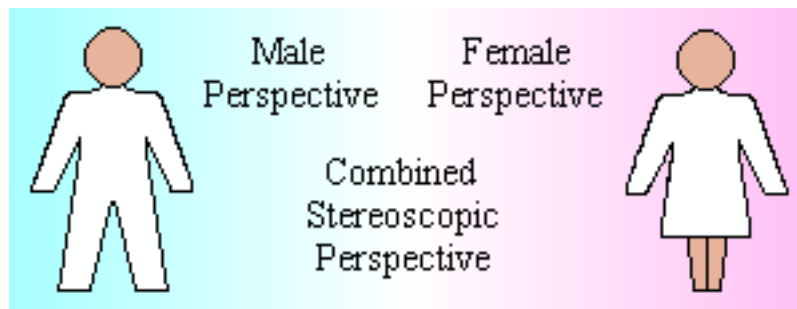

Thus when an inter-gender amoral relationship forms, these slightly different emotional perspectives combine intellectually to generate a far richer *stereoscopic* world-view with an extra 3rd dimension, which gives significant added depth to their understanding.

## The Desire to Connect

Now let us imagine that '[To each has been given](#)'. The Lost Inheritance - each one's fair and rightful share of the economic resources of Planet Earth - has been returned to him in accordance with a new and fair [universal constitution](#). Now, in the absence of the old forces of religious fear, political subjugation and corporate greed, what *new force* can drive the one billion distributed self-sufficient families of the Earth to self-connect into an integrated society?

The answer is, of course, this powerful emotional drive - or amoral force as

described above, working to drive relational connections between the *relationship receptacles* or *valency spheres* latent within every human mind. So in what pattern or configuration would this cause individuals to self-connect? It all depends on the numerical value of human amoral valency - the actual number of *relationship receptacles* or *valency spheres* nature has built into our minds or consciousnesses.

If humans were naturally monogamous - if nature had given each of us only one single *relationship receptacle* or *valency sphere* - then human society could not connect at an intimate level. Driven by the human mind's lesser but malevolent twin forces of greed and competition; state, religious and corporate hierarchies would once again materialise to enslave humanity.

## An Intimate Chain

A natural *intimate valency* of *two* is the minimum necessary to enable human society to connect completely. This complete interconnection would, however, be constrained to the form of a very long chain.

Young people would start off as isolated newcomers. Each would then somehow have to pair up and then either break into the chain or join at the end.

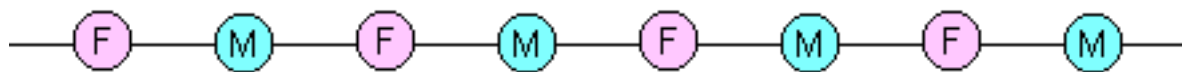

This could only really work if each new pair had progressed to the intimacy of marriage before joining the chain.

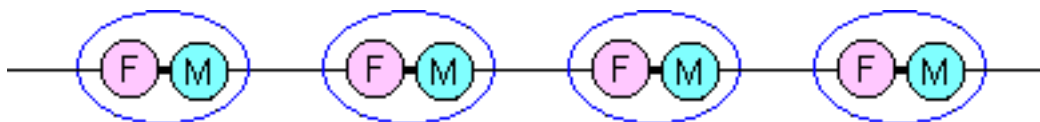

Even so, with only two ends available for the whole of humanity, this process would inevitably involve severing the established relationship between the two individuals at the point where the chain had to be broken to allow the new couple to join. It wouldn't really work. Besides, only people close together in the chain would have any real sense of being intimately connected. The number of degrees of separation with most other members of the human race would be vast.

## The Simple Network

A natural *intimate valency* of *three* improves the situation considerably. Three is the minimum necessary to enable human society to interconnect in the form of an *intimate network*. This vastly reduces the degree of separation between members of a local community. In fact, it binds them together quite closely.

In this model, young people mix socially so that each forms intimate links with up to three different members of the opposite sex at the same time. These links make and break dynamically until each individual's three links are with people with whom he or she has grown into deep and responsible friendships, as shown below on the left.

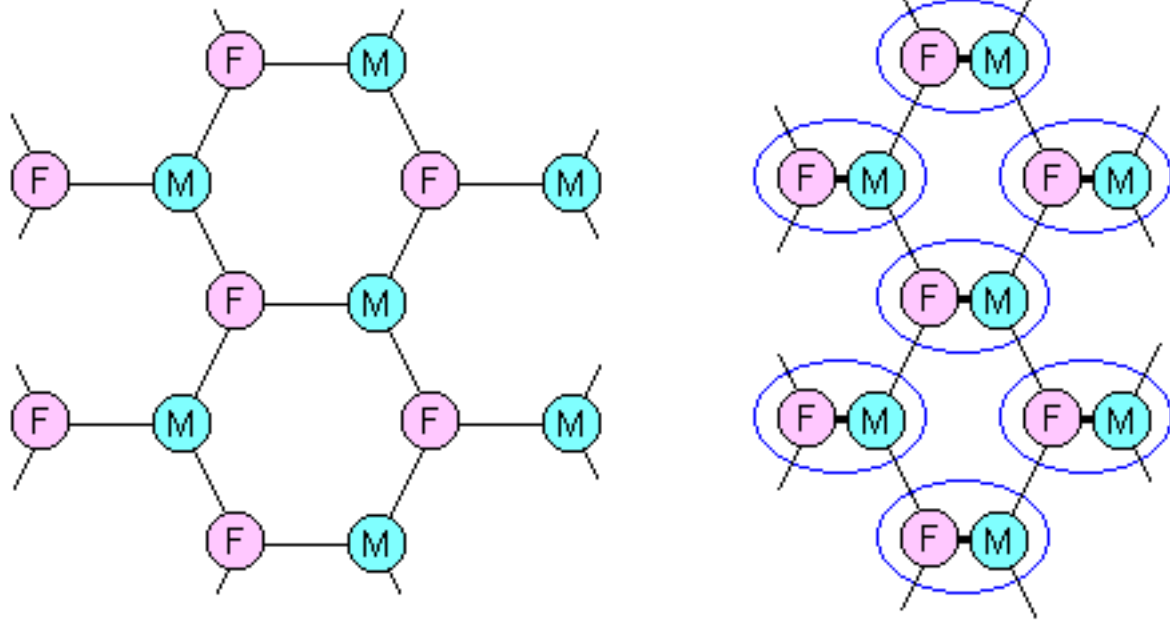

One of each individual's three links then intensifies to the point where they, and the person to whom this link connects them, decide to marry and establish a home and family together. However, in so doing, the new husband and wife do not in any way neglect or diminish their other two respective intimate links. The final result is that each wife remains intimately connected to two other married men besides her own husband, and vice versa. Thus, in this form of marriage, which I term *conservative polyamory*, marital domains become all linked together into an intimate network, as shown above on the right.

An intimate valency of 3 thus manages to link marital domains together into a *two* dimensional network. However, even in a [natural community](#) size of between 100 and 150 adults, this means that the intimate connection between most members is still via quite a large number of links. On a global scale, the degree of separation between any two individuals will still be absolutely enormous.

I would just like to make clear at this point that the network diagrams in this article are not geographic representations. Connected males and females are not necessarily next door neighbours in any literal sense. The diagrams are simplified schematics that show *logical* connective layouts: not *physical* ones.

## The Small-World Network

A natural *intimate valency* of 4 improves connection even further. It facilitates what is known as the *long reach* link. This is where a male and a female who live quite some distance apart share a fourth intimate connection, which is in addition to the one each has within his and her respective marital home and the two each has within his and her respective local community.

These *long reach* links may best be forged before marriage at the stage in life when young people have the opportunity to travel widely on educational trips and group holidays. These are illustrated by the red links below on the left.

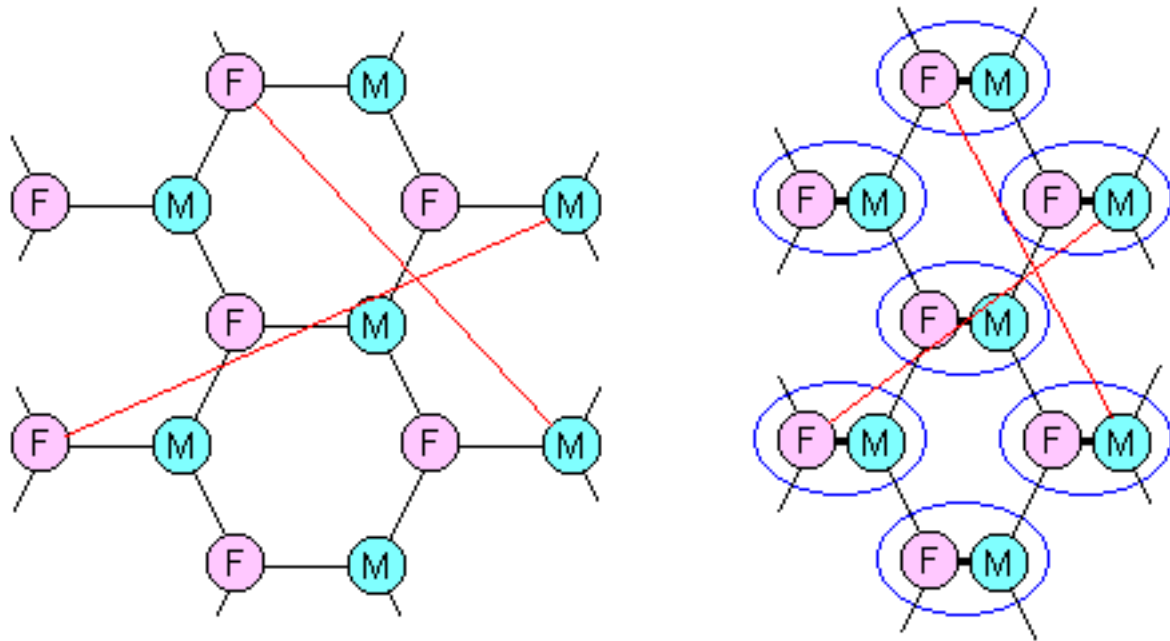

However, there is no reason why these additional links cannot be established after marriage when travelling for trade or social reasons as illustrated by the red links above on the right. *When* they are established does not matter. What matters is that those who link in this way choose each other responsibly and that the relationship is rooted in firm friendship and is lovingly sustained.

The great benefit of the *long reach* link is that only a few of them are needed to reduce enormously the degree of separation between everybody. A network with a few of these additional *long reach* links is called a *small world* network because this great reduction in separation makes people far more closely connected, thus making the world appear much smaller.

Of course, an even higher valency would vastly increase the degree of connectivity even further. But since a global intimate network has never been available to monitor, we do not really know what range of valency would result in that kind of social environment. However, a range between 2 and 8 permanent links per individual seems workable, with 4 being about the mean, although any

individual is completely free to establish as many relationships as he or she can *responsibly* sustain. The range and distribution would be the same for both genders.

The formation of the intimate network as described above assumes linkage occurs only between peers of the same generation. For a complete intimate network of humanity, inter-generation connections would also have to form. Perhaps in this future society, young adults would be initiated by a dear friend about half a generation older as part of their coming of age, which would then mature into a life-long intimate liaison.

## **Interracial Links**

In a global intimate network of all humanity, a small but necessary number of *long reach* links must undoubtedly be interracial. I don't think such links would eventually result in a world of coffee coloured people. On the contrary, I think genetics will always preserve the rich variety of the human species. Humanity can no more merge into a single racial type than the two sexes could merge into a single hermaphroditic gender. Whatever happens in the short term, I think genetics will always throw back the rich variety and differences with which we are all familiar, and in which we should all rejoice.

I have heard it said on television documentaries about genetics that an individual tends to be sexually attracted only to certain members of the opposite sex who are not too distantly related. In other words, one is attracted to people who are part of what they call one's *genetic village*. But then, this kind of attraction only occurs between a small minority of very specific individuals within this so-called *genetic village*.

But this is not all there is to it. I am white Anglo-Celtic. Almost universally, I find women of other races - though beautiful in their own way - totally neutral sexually. Yet I have found myself very occasionally strongly attracted to women of a different race. In my entire lifetime that has amounted to no more than three. I sensed the attraction was mutual. Nothing happened. Nothing was ever said. The significance is that none of these women could possibly be in any way part of my close genetic village.

Whatever it is that generates amoral attraction between two individuals may be more prevalent the closer they are genetically, but it also makes an appearance - rarely but just as strongly - all the way out to the most distant reaches of the human species.

The vital set of signals that trigger mutual attraction must include something else. It may be a genetic phenomenon or - for all we know - it may result from some kind of exotic close-dimensional coupling through the hyperspace of

human consciousness. Whatever it may be, it certainly provides the natural drive for human beings to self-connect into a global *intimate small-world network*.

But what are the necessary and sufficient conditions for humans to self-connect in such a way as to form an intimate network that has the particular and desirable all-inclusive *small world* configuration? In other words, what kinds of people must be mutually attracted to each other for this to happen?

## **The Right Personality**

Likes attract! So they say. One is advised and encouraged to marry somebody who is of a similar personality. Internet dating sites have pages of tick boxes to determine your personality, interests and preferences with a view to matching you up with somebody similar. This process produces couples whose composite personalities are the same as their individual members - incomplete and unbalanced.

With similar traits and aptitudes a couple - left to themselves - will naturally tend to compete with each other. They will thus tend to argue, dissipating each other's energies unproductively. It is only the complementary nature in their gender difference that struggles to keep them together. And that all too frequently fails.

It is only when managed within a hierarchical structure that such couples can be made productive as separate individuals. And this is exactly what the architects of present-day mainstream society want - couples who lack at least some of the faculties necessary to operate as balanced co-operative teams. Couples who cannot easily connect beyond themselves. Couples who can be kept separate and thereby controlled as individuals within a willing exploitable consumer workforce.

If *likes* naturally attract, humanity cannot naturally self-connect into a *small-world* intimate network. Highly valent extroverts would mutually attract, quickly forming their own closed highly promiscuous sub-nets. This overly connected structure would tend to promote the rapid spread of STDs. Low valency introverts would connect to a much lesser extent. Most would probably form into closed couples. Many may not connect at all. The kind of intimate network that would result would be very fragmented and largely dysfunctional as an means of unifying and enhancing human society. Indeed, it would tend to polarise society into adversarial factions.

## Complementary: not Similar

But suppose that our cherished notion of *like* personalities attracting is a fallacy planted in our minds from an early age by mainstream indoctrination. Suppose we remove gender stereotyping, pride and jealousy. Let us all just be equal sentient beings, each making the same good use of our very capable minds. Let's make *rational* choices.

I think we would then honestly discover that underneath all our social conditioning we are each mainly attracted to people not of a mutually *similar* personality, nor of a mutually *opposite* personality, but of a mutually *complementary* one. Put in a rather over simplistic way, introverts are attracted to extroverts who have *similar* values and interests - and vice versa.

This would result in the formation of couples whose composite personalities and aptitude profiles were complete and balanced. Each couple would be a balanced and capable team. So instead of tending to compete, they would naturally tend to co-operate. And this would be true not only for *primary* or *intramarital* couplings: it would also be true for secondary or *extramarital* couplings. Again, the chemical analogy is useful. Elements that self-connect to form molecules are those with *complementary* electron shell structures; not similar or opposite ones.

The upshot of this, that is relevant to the formation of a global intimate network, is that *complementary* attraction will mean that links will tend to form between individuals of [complementary valency](#). Thus high valency men will link with low valency women, while high valency women will link with low valency men. And this will guarantee that a self-connecting intimate network will take on a fully connected small-world configuration. This pattern of connection provides the minimum separation between any two individuals while providing maximum buffering against the spread of STDs.

Of course, there is perhaps one little rule that should be applied to make sure that society would thus form into an optimized all-inclusive small-world network. Reciprocal relationships should be discouraged, since these would tend to result in the formation of closed cadres.

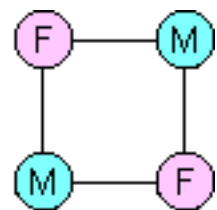

It is as if nature has purposely scattered the broad spectrum of human personality traits and aptitudes randomly and unevenly throughout the entire human race like scattered seed, leaving each of us with an incomplete and unbalanced profile. What better way could there be of making us need each other, thereby evoking within us an irresistible desire to connect.

This is why no honest princess will ever find her *one and only* prince charming. No languishing lady will ever find her *one and only* Mr Right. He does not exist.

In fact he cannot exist. It is as if nature has somehow imposed a fundamental *exclusion rule* preventing her ideal man from becoming embodied in a single individual - as so forcefully evinced by the endemic failure of monogamous marriage in present-day society now that the external forces of religious repression are fading.

But though she will never find her *one and only*, the lady will soon find a lovely guy who fulfils a large part of her ideal. And she will soon find others who between them fulfil the rest. So Mr Right does exist, but as parts of several different members of his gender. And this is so much better. Her multiplexed relationship with the composite Mr Right is far more robust, interesting and refreshing - especially in the long-term.

## **A Behavioural Attractor**

Human beings are creatures of extreme, not least in their sexual behaviour. Social norms in different places and epochs range from repressive celibacy to rampant promiscuity; from puritanical monogamy to incest, homosexuality, bisexuality, sadomasochism, paedophilia and bestiality. A casual search of the Internet reveals that all these extremes are alive, well and quite prevalent in today's world. They ebb and flow in endless chaotic cycles as popular frustration reacts against authoritarian constraint. They seem to be in a queue in which each waits its turn to gain legal acceptance to assuage minority prejudice.

I do not wish to project any *moral* criticism at practitioners of any of these extremes of sexuality in today's stressed and difficult world. However, looking purely from a *systems analysis* point of view, I have to say that they all appear to a greater or lesser extent to be at least biologically dysfunctional, and perhaps even psychologically damaging. Again, from a purely *systems analysis* point of view, they appear therefore to be not natural norms of human sexual behaviour, but greater or lesser externally-forced perturbations from the relaxed natural norm of *conservative polyamory*.

All these so-called *abnormal* modes of sexual behaviour are, of course, still natural. After all, they occur to some degree within the animal kingdom, although I do not think species-specific modes of sexual behaviour are necessarily systematically valid models for human ones. In any case, animal populations also suffer from oppressive externally-imposed forces - such as being caged in zoos or displaced by modern farming methods.

Celibacy, monogamy, homosexuality, bisexuality, incest, paedophilia, sadomasochism and bestiality - are nevertheless all *real* modes of human sexual behaviour which are all present from time to time in both minority and majority sectors of society. But this is because natural adaptive systems - especially ones as complex as *human socio-sexuality* - have the built-in capability, when severely disturbed by unwelcome external forces, to defend themselves by switching into *inert* modes of behaviour that temporarily reduce or suspend their contributive functionality.

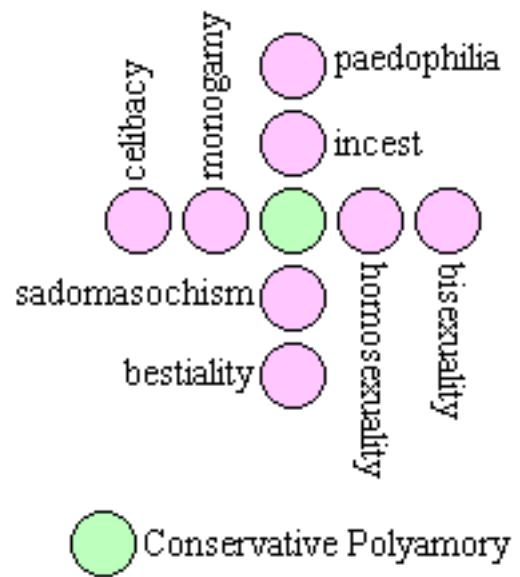

In other words, these alternative modes of sexual behaviour are the ultimate safety valve to dissipate lethal internal stresses resulting from outside pressures to which human society never ought to be subjected. These pressures are probably felt most by those who take them head on by refusing to be perturbed by them, stalwartly steering the healthy middle course of *conservative polyamory*. It is - perhaps ironically - these determined sojourners of this present estranged era who are perhaps the most in need and deserving of [professional help](#).

The forces that perturb normal human sexual behaviour towards these extremes are those of the repressive social, religious, political and commercial hierarchies of the influential elite who presently orchestrate the way we live! It is they who have driven the sexes to opposite extremes in dress, social and cultural roles, economic functions, emotional viewpoint and intellectual endeavour. It is they who have deliberately and forcibly driven men to Mars and women to Venus. So, for instance, is it any wonder that so many today can only find a remotely compatible intimate partner within their own gender rather than among what these malevolent hierarchies have turned into an alien species?

Of course, there will always be small localised perturbing pressures and stresses in any society, no matter how natural and ideal - just like the thermal noise in a communications system. So there is always bound to be an ambient proportion of deviant behaviour. But this should be small. And since the majority cannot know the particular pressures and stresses of the small number of individuals involved, society's attitude to the affected minority should always be to inquire and befriend: not to judge and condemn.

However, if all the authoritarian indoctrination and constraints imposed by the hierarchies were removed, the direct and consequential repression they cause

would also disappear. So would the popular reactionary and revolutionary responses to them. In the absence of the artificial perturbing forces from mainstream society, human sexual behaviour must naturally gravitate onto what, mathematically speaking, we would call its *behavioural attractor*. I am now persuaded that the natural behavioural attractor for human sexuality is the multi-hetero *intimate small world network* I have described.

This multi-hetero *intimate small world network* would then naturally become the main global transport backbone through which could flow a new rich plethora of emotional, intellectual and spiritual intercourse throughout all of humanity. It would be the fruitful vine from which all lesser social, economic and cultural relationships would radiate.

## Making Connections

The essential element of this new-age global intimate network is the small set of amoral connections each individual has with others. For clarity I shall try to illustrate this from the point of view of one individual. It could most likely have been John. But perhaps to be a little reactionary to present-day gender stereotyping, I decided to make it [Anne](#).

Anne is a typical product of this new connected world. She is an intelligent individualist with an impressive academic portfolio. Unlike her counterparts of the former world, she was not groomed to be a conformative cog of capitalism. On the contrary, she was actually taught to be an independently creative non-conformist, stimulated primarily not by what others think, but by her direct observations of the complexities of nature and society. She lives her life according to her own values, her disciplined sense of curiosity driving her continually to explore new yet benign possibilities.

She has been taught the new-age tenets of relational ownership - that no small elite can commandeer and amass terrestrial resources, that the individual owns the right of abode and economic yield of his *landshare*, not the land itself nor the right to exclude others from it. She was taught also that just as the total and exclusive ownership of another's life and labour is slavery, so too is the total and exclusive ownership of their time, loyalty, affection and intimacy.

Like all her peers of both genders, Anne received comprehensive formal instruction and training in both the erotic arts and the psychology of intimacy.

She learned the new-age genderless etiquette for exchanging a connective glance and initiating conversation. She was taught how to sense that essential affinity, which can occur only with that favoured few with whom she will have the potential for intimate coupling. She learned how to assess whether or not she and her mark had sufficient common interests, compatible values and

complementary personality traits with which to build a successful amoral relationship.

She learned, through the practise of neo-tantric techniques derived from rediscovered [ancient arts](#), how to trance with a guy through hours of rapturous intimacy, both of them emerging physically content and emotionally refreshed, ready to enjoy the intellectual stimulation of their topical/philosophical pillow-talk exchanged in the relaxed embrace of their post-coital euphoria. She even learned how to take full control of her fertility by gaining mastery of her inner reproductive processes.

She learned how to work with a partner to mould and steer their interests, values and personalities into an ever-closer resonance, thus strengthening the bond between them. She learned how to terminate a relationship with the compassion, care and consideration of a true friend. This was all a central part of her general tertiary education. It had to be. The robust operation of the amoral link is absolutely critical to the stability and health of the new-age global society in which she lives.

Like most of her fellows, Anne had difficulty grasping the historical concept of gender stereotypes. To all who know her - of either gender - she is simply a sisterly friend and a respected peer. As a female, her brain has certain natural gender-specific differences from the male. But in Anne's world, male and female brains do not show the enormous culturally-generated adaptive disparity they had in the old world. Women are no longer from Venus and men are no longer from Mars. They are complementary variants of the same species from beautiful Planet Earth.

Being quite an open and gregarious lady, Anne was usually the one to ask a more reserved male friend out on a weekend date rather than the other way around. Though she naturally took the lead in this way, no sense of superiority or disrespect for the guys she asked would even enter her mind. She had quite a few intimate relationships during her formative adult years. But she was never predatory. She had the deep and genuine love of friendship for all her guys, which was at the same time both erotic and motherly. She had been taught to recognise that each relationship is unique, making comparisons an unthought-of irrelevance never voiced.

Eventually, four of her intimate friendships strengthen to the point of permanence. These four very lucky guys have become her emotionally imprinted amoral partners for life. The love link between Anne and each of these 4 men has the permanence, commitment and formality of marriage. She is now a wife with four of what we could term *secondary level* husbands. Together they form part of a global network marriage.

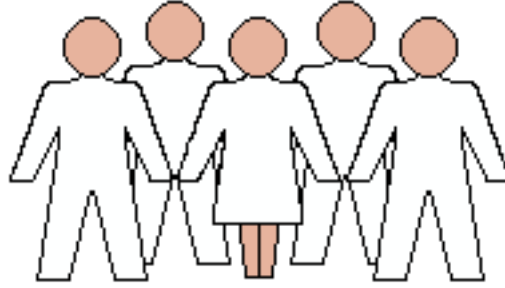

Of course she doesn't own the exclusive intimacy of any of her guys. The *spheres* of her mind link to only *one* of the *spheres* in the minds of each of her loves. Nevertheless, each *relationship* is unique and very special. Like her, each of her loves has been schooled in the principle that no individual can own exclusively the time, loyalty, affection and intimacy of another. Consequently there is never a thought of old-world jealousy between them over her, or from her over any of her loves' other ladies. Neither is there any notion of competition between her loves for a greater proportion of her affection. Each relationship is unique, and its bounds and proportions are determined by the relative sizes of the *spheres* in her mind.

## Primary Marriage

As her four intimate relationships develop, one of them starts to become particularly deep. Eventually Anne and her most special love decide to marry. They hope to have children. The human is the one life-form with the highest level of parental investment. Its optimal life-style must therefore be as a permanent nuclear family within a secure home. So as they marry, each claims his and her *landshare* inheritance. These are naturally arranged to be adjacent areas, which are then merged into a single [hythe](#). Here they build their marital home, in which they shall both live together and work together.

The home they build is quite different from the suburban brick box of the old era. It is specially designed to support a totally different lifestyle. It is set spaciouly in the middle of their combined landshare, which, through new-age technology, provides all their basic economic needs. Their house is a sculptured fantasy of linked ellipsoids and spires that blend harmoniously into the landscape.

One of its ellipsoidal units contains the couple's master bedroom. This is flanked by sizeable ante rooms, which provide considerable private space where each partner may independently think and reflect and keep things that are private and confidential to him or herself.

Another unit accommodates a soothingly adorned love nest, within which Anne and her husband can be completely private and comfortable together. Its main

feature is a richly upholstered dohyo about two metres square, conductively constructed to facilitate the perfect intimate encounter. It is here also on occasions that either may - without shame or secrecy - pleasure a visiting love.

Yet another unit contains a sanctuary in which they nurture and educate their children. And finally there is a flexible dining and relaxation section in which they welcome and entertain friends. Other outbuildings contain the storage and technological aids through which they are able to deploy their combined *landshare* to generate their basic needs of life.

## Polyamorous Lifestyle

Anne and her husband settle down into marriage. But the intimate connections with her other three loves are still there, undiminished and stronger than ever. Two of her guys have married and still live locally. One met a foreign girl while away on an educational exchange. He has since married her and moved to be with her in her far country. Anne now has three children. One of them is not genetically her husband's, but that's OK. Her loving husband welcomes all her children as his own, knowing that perhaps nature has given him a similar gift through one of his other loves.

Thus she has a husband and three children in her nuclear family, plus two local links and a long-reach link to an intimate friend in a distant country.

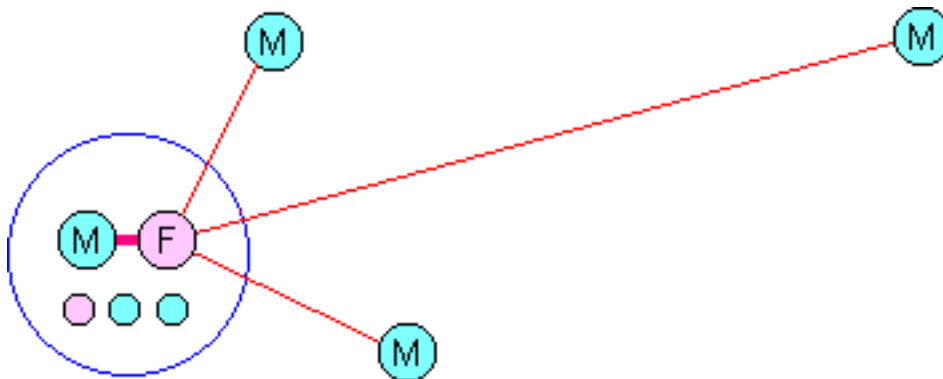

Though sex be the driving force that initiates and sustains all her intimate connections, its purpose is to facilitate emotional, social, economic, intellectual and spiritual interchange between her and each of the men she loves. She, like every adult, is thus an included and vital member of a global society linked by love.

Her husband has a personality *complementary* to her own rather than opposite or similar. She may be a little gregarious and he may be a little more solitary, so that together they present a balanced personality to the outside world. His weaknesses are her strengths and vice versa, so as a couple they are strong. This will of course mean that Anne's skills and experience in some things far exceed

those of her husband. But that in no way diminishes the intense and unshakeable respect she has for him. Their marital bond is unbreakable. Ideally it will last as long as they both shall live, but in any event it will remain at least until all their children have grown up and left home. Even if they part domestically, they will still remain lovers for life.

Each of her three intimate friends is now married and living with his wife in a nuclear family. But he could have been single initially. Each of these also has a personality that is *complementary* to hers. She naturally and responsibly chose guys who were similar to her husband. So, since as it happened, one of her children was fathered by one of her friends, it is perfectly compatible in physique and disposition to those fathered by her husband, and injects an enhancing modicum of variance into the family dynamic.

Anne has an interesting and busy life, taking care to share herself fairly between each of the men she loves, as well as her children, friends, work and community. She also puts aside adequate time to be on her own in private. Although she spends most of her time with her husband, she visits with each of her other loves regularly but not too often.

## Secondary Love Nests

In addition to the love nest that is present and essential within the marital home of each primary couple, there is ideally a separate *secondary* love nest for every secondary relationship.

I see the [secondary love nest](#) as the futuristic equivalent of the vacation chalet or one-bedroom cottage. My vision is of something like a large ocean buoy or round contemporary water tower raised off the ground on a central round plinth or struts. This would contain all the compact comforts and conveniences for a couple to spend the odd couple of days together. It would also be home to all kinds of little shared things that are special to the secondary couple to whom it belongs, thus making it their special shell of refuge - a tangible representation of their loving relationship. A secondary love nest could be mobile, but it should generally be at least transportable so that it can be installed quickly about half way between each partner's primary home.

Thus whenever Anne entertains her husband - her primary love, she naturally does so in their love nest at home. But when she entertains one of her secondary loves alone, she will usually arrange to meet him at their own secluded private love nest half way between their marital homes.

## A Loving Encounter

When she entertains one of her loves, Anne looks forward to sharing the preparation and eating of a romantic meal for two, then leading him by the hand to where they slowly undress and caress in the comfortable warmth.

Foreplay completed, she lays herself down on the dohyo, drawing her knees up to her chin in foetal style. She motions him. He knows what she wants. He lays himself on his left side cross-ways below her to form the familiar [sideways position](#) she had practised and favoured during her formal initiation. He welcomes her choice with a knowing grin. He lifts his right leg. She drops both hers, one each side of it, pulling back her heels to hold him. He quickly loops his right leg around her left, locking his right foot around his left leg, which he holds straight. She hooks her left hand tightly behind his right knee. They pause in readiness.

Then with a sudden pull on his knee she consummates their connection, her yearning flesh welcoming his eager penetration. He locks his legs tighter and pushes further. They exchange mischievous smiles, then clasp their right hands as if ready to arm-wrestle. At a flick of her eyebrow, they tense their biceps and heave together. In it drills to the ultimate depth as, with a little shriek, she tightens her hold on him with her heels. The thrill of his glans nestling deeply within her floods her mind with euphoric relief. This is comfort. This is home. There is nothing to do. There is nowhere to go. There is no space for cares - just blissful anticipation of two wonderful hours of well-deserved ecstasy.

They work gently upwards and onwards. The tempo climbs. Then suddenly a slight rotational twitch of his hips hammers her G-spot. She feels a contraction. Then one of his. They are almost there. They must go no further. They must not yet drift over the cliff of culmination. So in perfect synchrony they instantly tense and draw in the deepest breath. His chest inflates. Her breasts heave upwards like surfacing submarines with conning towers standing proud.

From here onwards, their formal training balances them instinctively, each the other upon the cusp of orgasm. As thus they *ride the tiger* forever together, time stands still. They gaze openly into each other's eyes. Their joined minds swirl from the subatomic depths, through the glory of the galaxies to the outer reaches of reality. Their united love wells outwards to every corner of humanity. They reminisce about events they have shared and wisdom they have gained. Then eventually, as afternoon fades to dusk, they signal their mutual consent to sail gently together over the edge into the joy of their convulsive conclusion.

They stay locked together in stillness for a little while longer, then disconnect. They thank each other sincerely for the willing gifts of pleasure they have just exchanged and shared with nobody else, in a unique and private event so intense

that it must have indeed left a most indelible imprint upon the consciousness of space-time. They pull over the duvet and smuggle down, cuddling each other tenderly in peaceful sleep until the high-summer morning light, each lavishly re-charged with the power to overwhelm any challenge that life may force upon them.

Naturally, not every encounter has to include full sexual intercourse - especially as Anne and her loves become older. But all will at least include intense emotional and intellectual intimacy within the comfort of a long cosy cuddle. Anne is often happy just to snuggle up to the warmth of his firm fit body while he is content to sink blissfully into her soothing softness. The genitals may be more sensitive, but the skin that covers our entire bodies is by far our largest and most all-encompassing sense organ.

Nevertheless, as they were forewarned strongly during their formal education, physical sex should never be neglected - even in the twilight years. And it should be encouraged for everybody. This is why, beside the dohyo in their love nest, Anne and her husband have a beautifully engineered yabyum facilitator, the essence of which is a facing pair of softly upholstered fully-gimballed motorized saddles. Anne acquired it for her husband because one of his other loves is physically challenged and cannot perform successfully on the dohyo. But she has no problem on the facilitator. Besides, it will become useful to them all as they reach towards their latter years.

In this new age, everybody's multi-valent intimate potential is completely fulfilled. This allows ordinary non-amorical (or Platonic) friendship to be truly independent of gender. It is all so different from the previous age in which societal undertones always imposed a certain awkwardness upon the notion of a separately married man and woman even being one-on-one friends, let alone openly spending uninhibited intimate time together.

## **A Lady's Sexual Diary**

Anne's general formative education had included instruction in how to share herself fairly and appropriately between her loves. She must *see* each of them frequently enough not to let their love grow cold, but not too frequently as to leave insufficient time for the other things in her life. She therefore sensibly bases her shared time on her natural monthly cycle, organising her diary to spend a night and a day each *month* with each of her secondary guys, and the rest of her intimate time with her husband.

A month between encounters may seem a long time, but it means that each time she and one of her guys *meet*, they are that much more pleased to see each other again and have lots of news to catch up on to spark off and maintain good conversation. It is not always possible, however, for her to see her distant love

every month. Yet he is just as important to her as the others. Her visits to him are consequently less frequent and often sporadic. However, they do fulfil a very useful secondary purpose.

Anne's husband is her ideal complementary match. They are deeply in love and give each other perfect happiness. However, he is more solitary than she is. His appetite for intimate connection is less than hers and he has only two secondary partners to her three. Among other things, he is a writer. During a writing project - which adds up to about three months a year - he spends long periods in uninterrupted concentration during which he is necessarily incommunicative and unresponsive to those around him. Writing consumes vast amounts of his mental and emotional energy, leaving little or no time for his family during a writing project - especially Anne. Back in the old days of monogamist marriage, the faithful wife's justified frustration with her husband's lack of attention in such circumstances led to a high separation and divorce rate.

However, unlike a faithful wife in a bygone age, Anne has the independence, initiative and opportunity to take a short holiday on her own to visit her distant love during her husband's periods of concentration. She may sometimes take her children with her. Other times they may stay with their grandparents who have now moved into a smaller home in a corner of Anne's landshare.

Anne enjoys her holidays. The sexual pleasure, emotional refreshment and intellectual stimulation exchanged with her distant love, keep her happy, satisfied and full of vitality right through her husband's solitary times. So when she returns, she is a self-sufficient source of inspiration and emotional support to her husband during the very times a wife of the old world would have been nothing but a frustrated demanding downward drag.

These practical considerations of encounter scheduling impose a workable limit on each individual's *deployable valency*, which it is hoped will match the natural valency with which nature has endowed them. A few high valency individuals may have to extend their schedules to span two or even three monthly cycles. Some may prefer a more sporadic timing to their encounters. Nevertheless, the negative compensation provided by the practical limit on responsible valency deployment keeps *intimate valency* operating within a benign range, thus avoiding the *scale-less* runaway madness found in some old-world surveys on [human sexual contact](#).

## Network Heartbeat

Because there is always bound to be at least some asymmetry between the cycles of their different loves, every guy in this new-age society is always going to have some degree of challenge arranging his diary.

The rhythm of the global intimate network - like that of most artificial communications networks - emanates from the indirect coupling between lots of independent system clocks. In this case, millions of female cycles buffered from each other only by the connective channel of common male intimacy. This connective channel is a biochemical and emotional signalling path that may well tend to pull all female cycles into synchrony, while at the same time ensuring that it never quite does so.

The clock-tick of the global intimate network may thus become a little like the regular rhythm of the heart, upon which is modulated the undulating melodies of the mind. This regularity tempered with a little irregularity is healthy. It maximises communication through the network while guarding against potentially destructive resonance.

## Intimate Teams

Professionally, Anne is a biologist. Her socio-economic contribution to humanity is her research and development project into better fuel-yielding plants. In this work, she leads and co-ordinates a team of helpers. This team comprises her four special guys whom she has taught and nurtured in the subject. Together they farm experimental crops in a corner of her landshare. She has another experimental crop plantation in a corner of the landshare of her distant love. He lives in a part of the world where the climate is slightly different, and she wants to perfect a variant of her crop that will thrive in both climates.

Anne's five-strong biological research team is like a pentagon. It is an egalitarian team in which each has his/her own special role. Anne is the one with the technical knowledge and the leadership role. As members of her team, her guys have to get on well with each other. But their relationships with each other are lesser and fundamentally different from their relationships with Anne.

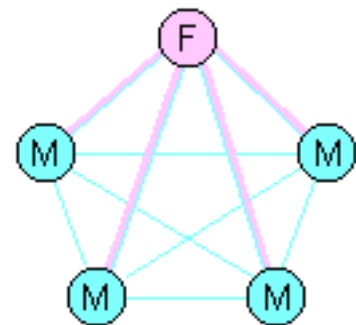

For a start, her guys have *similar* rather than *complementary* personalities. It is in this context that *likes* attract. The mutual attraction these guys have for each other stems from their united quest to fulfil perfectly and completely all Anne's sexual, emotional and intellectual needs, which each knows he cannot do alone. So they need each other. Their common goal can be achieved only through fraternal co-operation. And part of fulfilling Anne's intellectual needs is to make her biological research successful.

The smooth operation of her biology research team is ensured by the fact that Anne's bond with each of her team members is of a far stronger type than the

mutual bonds between the members themselves. Its sexual dimension facilitates a vastly greater band-width for interpersonal communication, resulting in a far more intense interpersonal commitment. Thus it seems that the ideal team dynamic is where every member has regular sex with the boss, but never with his team-mates! It must however be borne in mind that Anne's open and responsible relationships with her team members is the ultimate moral antithesis of the deceitful seedy office affairs of the old corporate world.

Though she is the leader of this team, she is also a lowly member of other teams. Each of these teams is led and co-ordinated by one of her four special guys. Her team mates in each case are that particular guy's other intimate females. Her husband leads her and his other two loves in a literary project. One of her local loves leads her and his other ladies as one of the teams in a global group that organises the distribution of food and the other needs of life to parts of the world where this year the rain did not fall in due season nor the sun shine before the harvest. Her other local love leads her and his other ladies in a musical quintet. Her distant love is a communications engineer. Part of the time she spends during her more prolonged visits to him is as a vital member of his team in their quest to help improve the world's physical communications infrastructure.

So Anne has her primary expert interest in biology, which each of her guys shares with her as one of his secondary interests, while each of her guy's primary expert interests are her four secondary ones. Of course, each of her guys shares secondary interests with each of his other ladies, which he does not necessarily share with Anne. It all makes for a diverse - and consequently very healthy - academic mix.

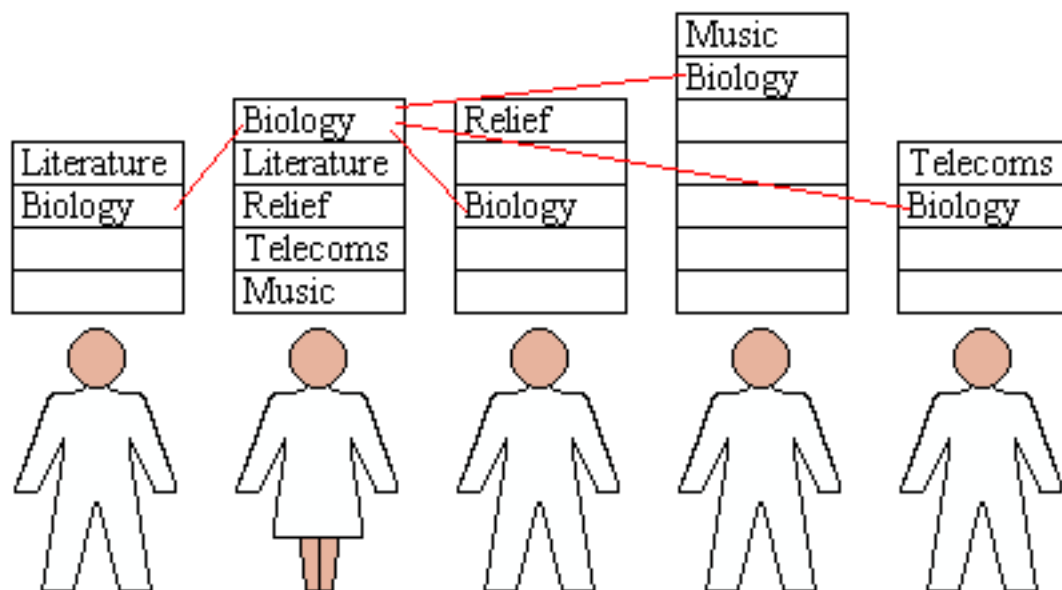

Anne, like everybody else in her world, belongs to as many teams as she has intimate partners, thus involving her in as many diverse economic and cultural endeavours.

## Other Loves

Her husband and her three peer loves are all of Anne's own generation. They were all at school and college together. But none of these was her first. Anne had been initiated by an older man 15 years her senior, whom she had befriended in her late teens and of whom she became very fond. Like most, this older friend will be initiator to only one younger person in his life.

He will remain one of her intimate friends for the rest of his life. She does not *see* him very often but she makes sure that not a year goes by without spending at least three special occasions with him. He is the one elder hero she will always look up to, and her most trusted source of wisdom on matters she would feel uncomfortable confiding even in her parents.

Anne gives presentations and seminars in connection with her professional work. During one such presentation, a young male student asks her advice on his future career choice. They become quite fond of each other and a year or so later, he asks Anne if she will be his Initiatrix and become also his official professional mentor and friend. She says she would be honoured. She thus becomes his partner throughout his formal training in the erotic arts and the ways of intimacy. In these she nurtures him, patiently perfecting his skills, feeding to him ecstasy as she would breast milk to her child. From this, he emerges a confident and valent Adept, ready to take his rightful place as a node in the intimate network of humanity.

Following the social norm, it is highly unlikely that Anne will ever fulfil this role for anyone else. She will guarantee to spend only three special occasions a year with him, but he knows that he can *see* her whenever he particularly needs her love, skill, comfort, advice and wisdom as he follows half a generation behind her through the often difficult challenges of life.

Thus Anne's intimate links now span not only her peer generation, but also those half a generation in each direction, thus helping complete the intimate network of the *whole* of humanity. And with this she is very satisfied.

## Personal Development

From her formative years and throughout her life, Anne has been able to explore a myriad ways of relating physically with her various partners in the complete absence of comparative criticism or mainstream disapproval. As a result, through her conservative polyamorous lifestyle, she now enjoys many physical, emotional, social, economic and intellectual advantages over her old-world forebears.

As a vital node within the global intimate network, she has ever present within

her a deep sense of *belonging* as an equal citizen, beloved sibling, respected peer and a free and able spirit within a caring world. And as if basking at a confluence of living waters, a bounteous sense of being *valued and desired* flows continually into her heart from her four erotic loves, who also - each in his own special way - feed her ravenous intellect, and are themselves her conduits to infinite social, cultural, economic, academic and spiritual contact through the intimate net.

This broad direct connection to collective humanity levitates her own self-awareness and draws out latent aspects of her personality, the glory of which would otherwise have lain hidden from the world forever. These in turn facilitate a deepening of all her social relationships, particularly enhancing the companionship she enjoys with her special guys and their other intimate ladies.

Her marital bond is free to develop and grow to heights unknown to her forebears. Her other loves complete her natural need for amoral multiplicity, so her darling husband can never be the object of blame for what he naturally cannot provide. And being the grateful recipient of so much joy in her life, she is fired with a personal mission to give joy to others.

## **Good For Children**

Anne's children are immersed in a community of multiple balanced role models. They see how the complementary personalities and abilities of their parents unite into a balanced composite whole through their intimate bond. But they see further diversity of examples in the couplings formed by Anne and her husband separately through their extramarital links. The environment of the intimately extended family is thus an extremely conducive nest for the personal and social development of all the children it touches.

Both Anne and her husband are very tactile with their children, as they were properly taught to be, thus imparting to *each* a balanced and receptive outlook through which to connect with those they will love and befriend in later life. And in accordance with the ordinances of her world, when each of her children reaches the decreed *age of wisdom*, Anne, like her husband, will formally cease to be her child's elder and become instead his or her loved and trusted peer.

## **Connective Infrastructure**

The strong sexual and emotional relationships Anne has with her guys provide vital links in a complete connective infrastructure of humanity. It is wholly egalitarian. Its links are based on personal love, integrity and trust. They form the backbone upon which is borne all social, economic, academic and cultural communication throughout the planet. It ensures equity. It keeps the peace.

After all, Anne would never allow even her husband to harm or swindle any of her guys. Because she loves them both. Strife between them would be strife between two of the *love spheres* within her mind. How could any defraud, harm or kill another, with whom he must be intimately linked by no more than a few degrees of separation?

So through her intimate connections, Anne buys and sells all her needs and surpluses in this idyllic world, which is at the same time both high tech and agrarian. Through them she pursues her life-long education and personal research, her social and recreational interests, and her spiritual fulfilment. Through them she gives to others her knowledge, experience and substance to help and counsel all whose needs they can assuage.

No predatory hierarchy like imperialism or capitalism could ever break the amoral bonds of this global intimate small-world network. Through its links of love, a society of this form would automatically dissipate the obscene extremes of economic disparity we see today.

And because it is fundamentally sexual, the *global intimate small-world network* links males and females in strict alternation. Every *amoral* interpersonal relationship in the world is between humans of complementary gender. Consequently humanity could never again polarise into the old gender-specific factions of male-dominated hierarchies and reactionary feminism. Men and women are one, in a world that has learned once and for always that 'only love can set you free'.

There are also many possible physical benefits to this kind of intimately linked society. For instance, the tight physical and emotional linkage between two people probably causes beneficial changes in each person's biochemistry, and hence their general physical and emotional well-being. An intimate network would doubtless propagate and augment these benefits throughout the entire population. A connected network may also facilitate bio-chemical and emotional signalling which could effect such things as natural automatic population control, thus reducing or even alleviating the need for contraception. All very interesting speculation waiting to be researched when and if such a world is ever realised.

To facilitate this global web of intimate connection, everybody in Anne's world must be able to travel and converse freely. It must therefore include an appropriate combination of physical [communications infrastructures](#). But that's another story.

---

[Start](#) of book. This page's [parent](#). [About](#) this book. About its [author](#). ©June 2002 Robert J Morton